

... , ...

()



2019

343.983.2(075.8)
67.521.4 73
65

-

65

, . . .

() :

/ . . . -

, ó :

, 2019. ó -

132 .

ISBN 978-5-7899-1179-2

()

,

,

,

() .

,

.

343.983.2(075.8)
67.521.4 73

: . . . , . . .

ISBN 978-5-7899-1179-2

©
©

. . .

. . ., 2019

, 2019

	4
1.		
	() 5
1.1.		
	()5
1.2.	()11
1.3.		
	()14
2.		
	()	
	19
2.1.	()19
2.2.	35
2.2.1.	35
2.2.2.	39
2.2.3.	67
2.2.4.	98
3.		
	()103
3.1.	 103
3.2.		
	() 113
3.3.		
	118

1

()

1.1.

()

, , -

, . -

() , -

- , -

. -

() -

, -

, -

, -

. , -

, -

:

- 1) - ;
 - 2) - ;
 - 3) . -
- () -
- , -
- . , -
- , () -
- 1996 . 150- « » (ó « 13 »).
- ,

(1) , -
1 , -
, , -
() , ()
. « »
, : ;
; .
6
: ,
: -
ó , -
, ;
ó -
, -
; ;
ó ; -
ó -
« »
() . -
() -
, -
- -

¹ .:

(ó),

ó , , , :

-

-

,

ó (.20.8);

ó (.20.11);

ó (.20.14).

-

,

,

(ó)

,

.

. 223 . , .4 .222 .4

.

,

,

,

,

(. 162),

(. 206),

(. 213) . (. 211),

()

,

(. 208),

() (ó).

195 ,

. 4 . 146 . -
27 -

. 1 . 80, . 204 -
«í -
, -
, -
».

() -
(. 196), -
, -
.

() -
, -
, -
.

31 2001 . 73- « -
- »

, -
- , -
.

() -
, -
.

, -
-

: 51215698 « -
 »; 5171562001 « -
 , -
 »; -
 5154962000 « -
 , -
 »; 5190562002 « -
 , -
 »; 5211562003 -
 « -
 , -
 » ó -
 , -
 () -
 () « -
 , -
 , -
 »¹. -

2010 .²

¹ .:

² . ., 2000.

2 . .1/ . . . ;, 2010.

1, ,

.

20 1993 . 4992-1 « », : «Í

ó ,

13 1996 . 150-

« » , 51215698 «

ó () .

()

2.

,

,

.

. 1 « », ,

-

,

1 () ,

,

,

2 ::

...

), , (-
, , - .
, , -
-
-
(,) ó , .).
() ó ,
, . . . -
.
. : ó .
, : .), (ó) (ó -
.
. () -
.
, () ó -
. -
(-
) , -
() .
« ó ».
, .
:
, « » : ó , , , -
« » () , ó , , ó

13.

()

() ,

() .

() ,

«1

»¹.

« »

«

»

2.

1

: . . . , 1970. . 6.

2

: 5154962000 «

»;

521156

2003 «

»;

(),

.6 « »

(),

ó

(),

()

« » ó

. ,
 -
 . () -
 .
 . (-
). , -
 . -
 . , . . -
 . , () -
 . , (.4 .223). -
 , -
 , -
 , -
 () , -
 . () -
 . , -
 , -
 , -

() -

.

() -

.

,

,

.

() -

)

.

,

(), - , , . (-

) , (-

) (-

(,

.).

()

:

ó (, , .);

ó (, , .);

ó , -

(, .).

:

ó (, -

);

ó - (, ,

);

ó - ();

ó - ().

ó - (, , :
);
 ó ();
 ó , « », ;
 ó (,).
 :
 ó (, , -
);
 ó (, , ,
 ,).
 () ó , -
 ,
 . - ()
 - 27 (60 lbs),
 ó 43 (95 lbs).
 () -
 (, -).
 () -
 . (-
)

2

()

2.1. ()

, () , -
 , -
 , () , , -
 () , . . . -
 ó () ,

(.1).

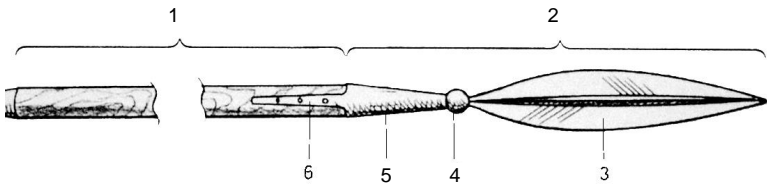

. I. 1 ó ; 2 ó ; 3 ó ;
 4 ó ; 5 ó () ; 6 ó

120 150 .

ó

(20 40)(.2).



.2.

(.3),

(1)

2 .



.3.

(.4).



.4. ();

()

45660 .

6

(0,7).

(0,2),
60 .

2

(.5).



.5.

IV6VI .

ó (1 .
, XV .,
ó XVII . (.6).



.6.

(263 ,
)
ó ().
,
(,) (.7).

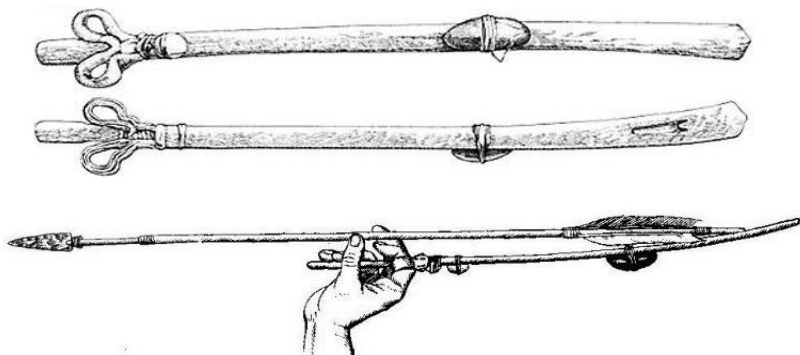

.7.

()
()
()

(.8).

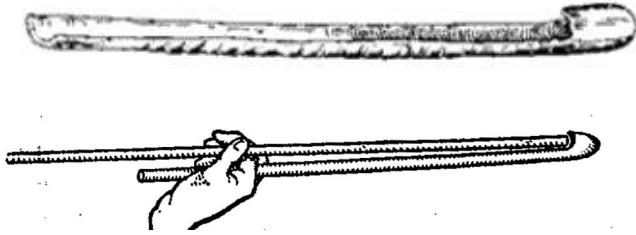

.8.

();
()

()

(.9).

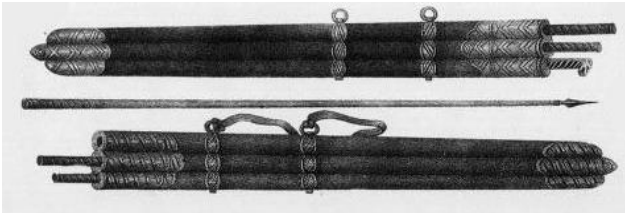

.9.

(. 10).

()

(

().



. 10.

ó ()

ó ()

51215698 «

»

ó 90 150 ; ó 200 ,

ó

;

ó

)

(

,

-

-

(. 11):

ó

,

;

ó

,

;

ó

-

,

;

ó

-

-

200 300 .



. 11.

()

()



. 14.

: (- , -) -
 , (). - ,
 , (; « » ó -
), (), (-
), (), (), -
 (), (50 - .
 - , -

(. 15).

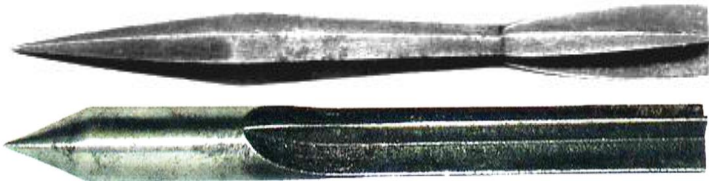

. 15. -

ó 150 300 . - ó 906150 , ó 5610 ,

(. 16).

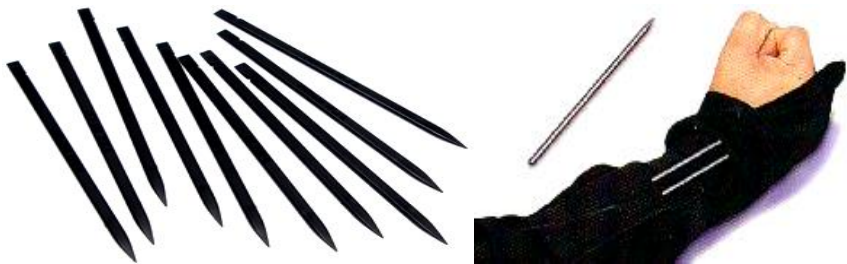

. 16. -

(. 17).



. 17.

ó () -

() ,

() ;

(. 18).

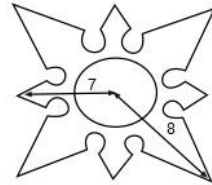
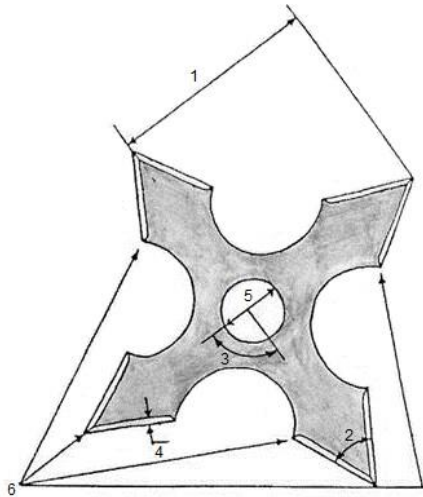

. 18.

1 ó
2 ó
3 ó
4 ó
5 ó
6 ó
7 ó
8 ó

; 3 ó

; 6 ó

:
;
;
;
;

60 300 .

6 8 .

6 6 , -

« » , () ,

« » ,

6

(. 19).

ó 1 3,5 10 30 , ó 10 40 ,



. 19.

, - ,
 , - ,
 ó (. 20).

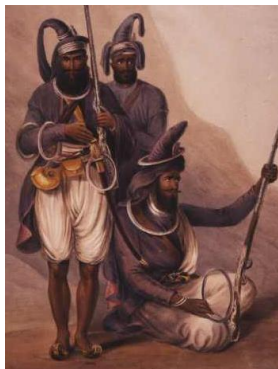

. 20.

- , (. 21). -



. 21.

50

(,)

ó ()

ó , ,

« »

»¹.

(. 22).



. 22.

¹ : 25 000 . 2- ,, . 2006. . 116.

, () , .
) 3:4.
 806120° ,
 (. 23). ,
 , .
 - .
 .
 ,
 .

160 .



. 23. ,

,
 ,
 (. 24).

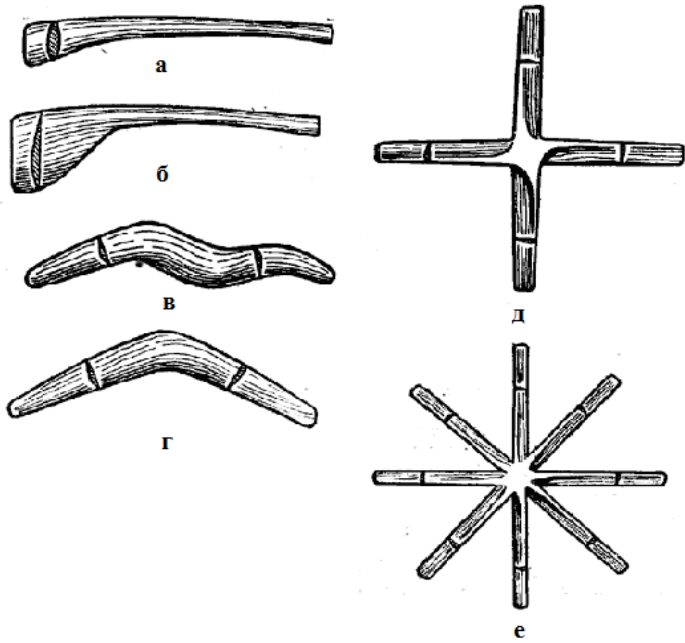

24. « - » (); : « » () (); (); (,) (50°), - - , - , - , - , - (. 25, 26).



. 25.



. 26.

2.2.

2.2.1.

«í»

»¹. « -
 « » -
 »². « -
 (), -
)(.27). (, -
 . 100 400 . ()



. 27.

() ,
 (.28).

¹ : . . . [.]. ., 1978. .499. 6 / . -

² /, 2007. .716.

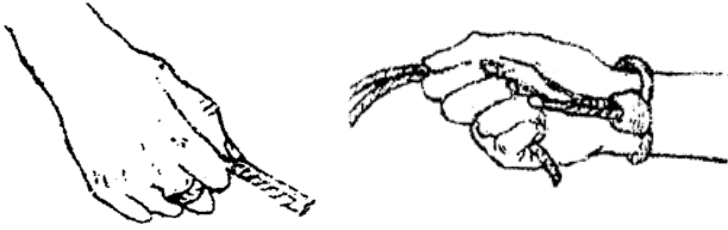

.28.

150 (.29).

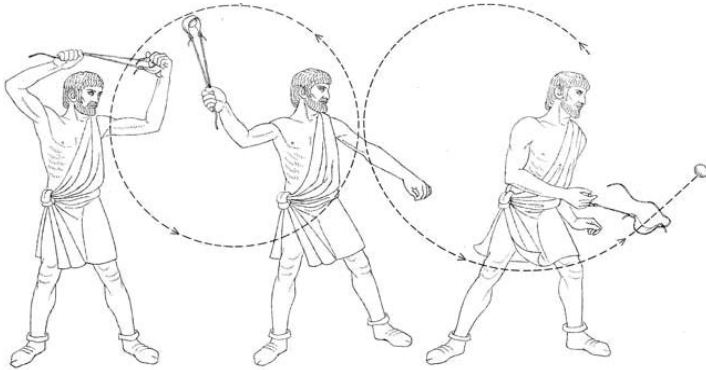

.29.

).

(. 32).



. 32.



(,)

2.2.2.

5154962000 «

»

«

».

12617 XVII .

(. 33),

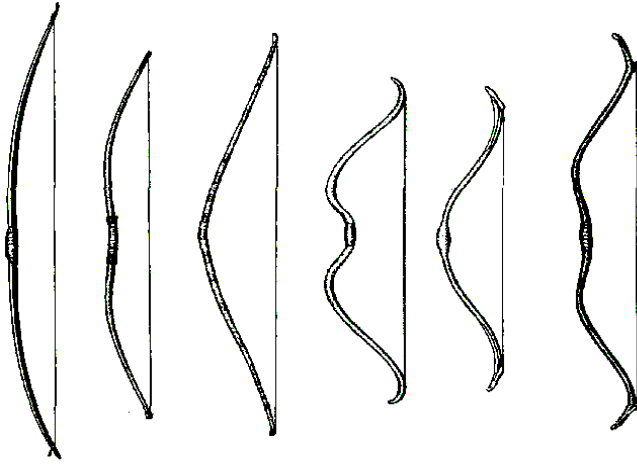

. 33.

:

:

XVII . () ; 6 6

() ;

() ;

() .

() ;

()

60

3

(. 34).



. 34.

) () (. 35).

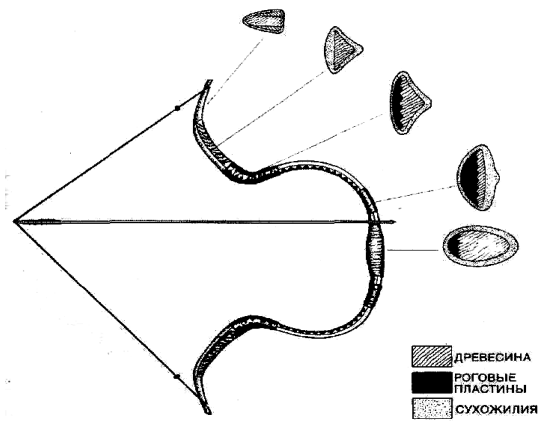

. 35.

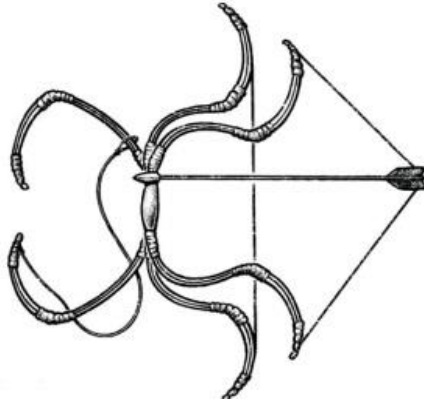

.36.

ó

ó

27 (60 lbs). ()

(),

27 (60 lbs).

(longbow), (flatbow)
(selfbow) (. 37).

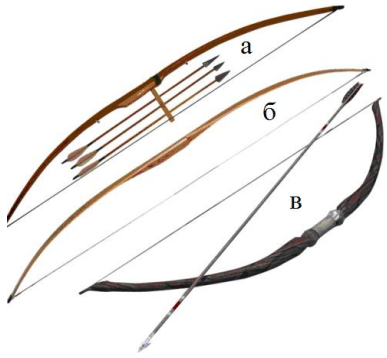

. 37. (); (); ()

ó (. 38).

¹ .: . 4.3 . 1, .
2006 . 386- .



. 38.

();

()

Bear (), Yamaha ().

Hoyt, Bowtech, Mathews, Browning, Beiter (), Spigarelli ()

(. 39).

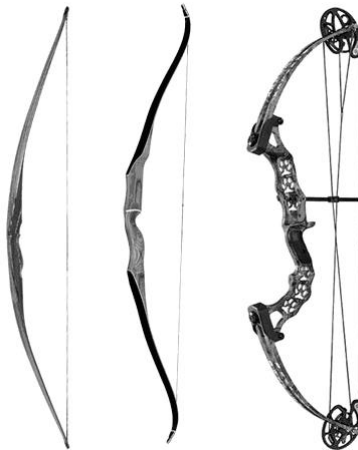

. 39.

();

();

()

(), ó , () 150 200 .
 .
 , ó lbs , .
 , ó 80 % .
 , 40 lbs (18,16) , -
 () ,
 () () , .
 () : , ,
 : .
 ó , () -
 , , -
 () , ()
 , , .
 ó () () () -
 , () () ()
 () .
 , ,
 , .
 1966 . ,
 1969 . -
 , , , -
 , , , (. 40). -
 , , , , . -
 , , , , .
 , , , , .



. 40.

HOYT MAXXIS 31

(. 41).

()

(. 42).

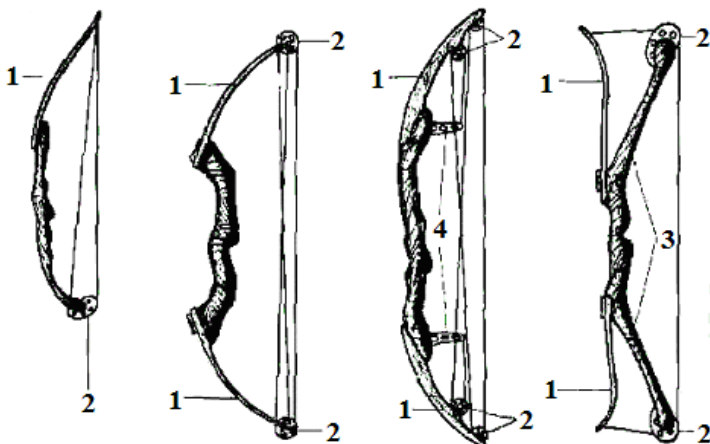

. 41.

();
1 6 ; 2 6

();
; 3 6 ; 4 6

: ();
().



. 42.

() .

() :

() ,

:

,

-

,

-

,

-

:

ó () ;

ó , ;

() ó , ;

,

;

ó ; -
 ó ;
 ó ;
 ó ;
 (() ó); ()
 () ó , ()
 ; () ó , -
 , , 26
 , 2- (~900) -
 , . -
 , . -
 , , Carbon Express, -
 , , Easton, -
 , ;
 , ó lbs ,
 , ó 80 % ;
 , ó () ;
 ;
 , ó ;
 , ó ;
 , . -
 (.43). -

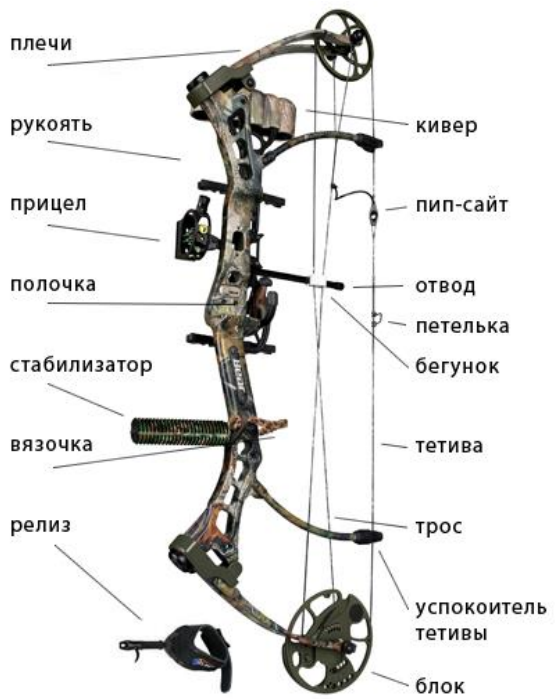

. 43.

() , -
 (. 44). -
 () -
 , -
 , , , .



. 44.

() ^ó (),

() (. 45). () , -

80 %.



. 45. -

ó , -

(. 46).



. 46. -

() (. 47).



. 49.



ó

(. 50).



. 50.

).

(. 51).



. 51.

(. 52).



. 52.

() (.53).



.53.

(.54).



.54.

(), (.55).

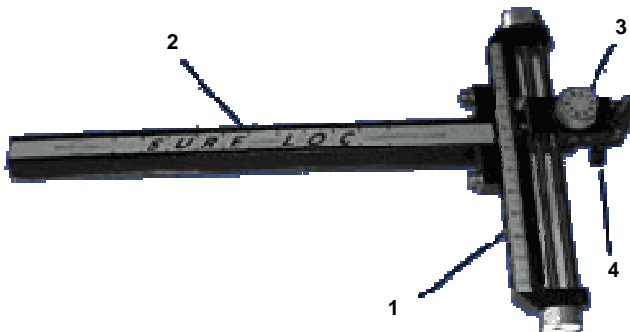

.55.
1 6 ; 2 6 ;
3 6 (); 4 6 ;

- ó ()
),
 (. 56).
 - , .
 ,
 . 56. -
 ()
 , -
 , -
 (. 57).
 , (-
).
 100 .



. 57.

6
(.58).



.58.

6
80061 100 .

1 500 .

(.59).



.59.

() (. 60) ;
 (,).

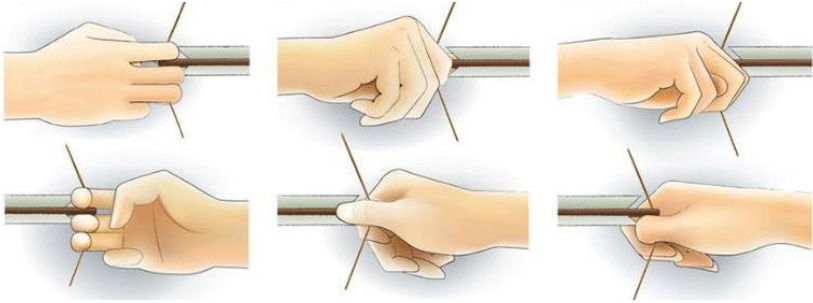

. 60.

, , ,
 ,
 ,
 ,
 (. 61).



. 61.

() ó -
 (. 62). -
 . -
 , -
 , .



. 62.

()

(. 63).

(),

()



. 63.

: -

();

()

(. 64).



. 64.

6

(. 65).



. 65. ()

()

(. 66).



. 66.

(. 1).

1

1376142	55657	137
1456150	57660	145
1526157	60664	152
1606165	64666	160
1676172	66668	167
1756180	70	178

(. 67).



. 67.

(. 68).

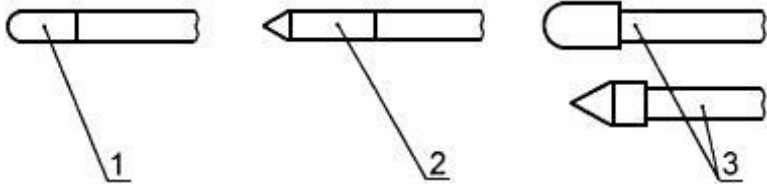

1 ó (. 68. ; 2 ó ; 3 ó)

(. 69).



. 69.

Shoker

S unders (. 70).

JudoPoint

Zwickey

« »,
,



. 70.

S unders

(. 71).

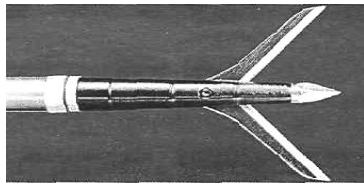

. 71.

(-): ();
() ()

6

(. 72).



. 72. :

();

();

();

()

, ó), , . (, -
 , .
 , .
 () -
 , ()
 ():
 ó (ó 0,005);
 ó 0,01 ;
 ó 0,005 ;
 ó 0,5 ;
 , () ;
 ó .

0,35 0,5 5 10 -
 , , -
 , « -
 »,
 :
 1/64 (0,4), ó
 (0,025).
 1816 18 × 0,4 = 7,2 ,
 16 × 0,25 = 0,4 .
 23°; -
 , , -
 , , -
 .

()
 () ó , -
 (. 73).



. 73. ()
 , -
 (-
), , , -
 , , -
 , (. 74). -

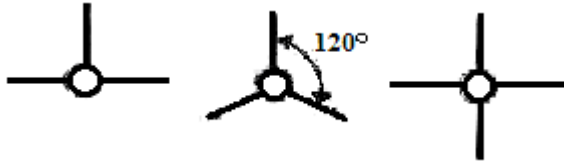

. 74.

: , ()

(. 75).



a



b

. 75.

(); () :

, , (. 76).



. 76.

2.2.3.

arcus ó (). ballista ó () ó . arbalete,

. . (. 77).

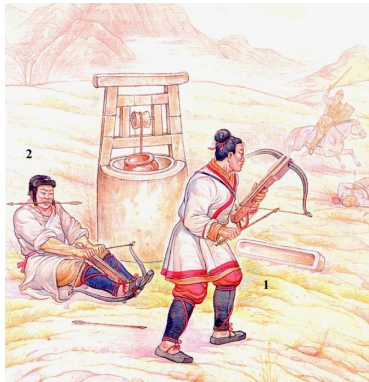

. 77.

(400 . .),
ó (. 78).



. 78.

, y
 XII .
 , ,
 , ,
 , () (. 79).



. 79.

250 6 30 . 100 . 300 4006500 ,

263 / ' ,
 ó (. 80).



. 80.

ó (. 81).
 (. *schnepper*) ó (. 82).

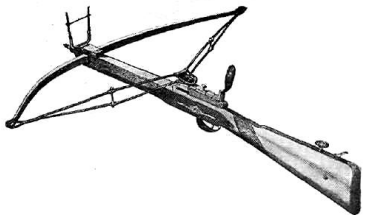

. 81.

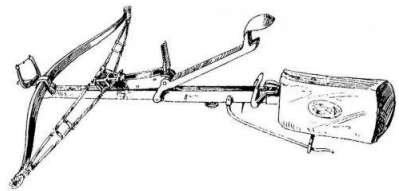

. 82.

(XVI .)

150

buse ó).

(. auquebuse, . arc ó

(. 83).



. 83.

(XVIII .)

XVI .

ó

XVII . (. 84).



. 84.

(. 85, 86).

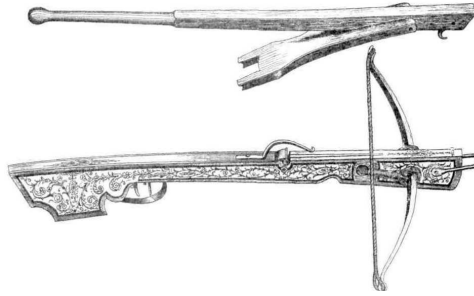

. 85.

(, XVII .)



. 86.

(-)

(. 87).



. 88.

(. 89).

60- (. 90).



. 89.



. 90.

Little Joe

1. () ó , -
 () () , -
 « » , -
 (1), 5154962000 « -
 » -
 914 43 (95 lbs), () ó
 762 4,5 . -
 43, 81 (160 lbs), -
 10 608 ,
 ó 30 ó 820 .
 ó 700 , ó 60 .
 6,75 (ó 10) 8
 (30). (,) -
 , -
 .

1 1.3, -

() 43 (95 lbs), ó -
 900 , ó 720 .
 ó 150 , ó 150 , -
 10 . ó 300 . ó

, 1.
 , 43 (95 lbs). , -
 , . ,
 , -
 , -
 , -
 (.4 .223).

. 1 « » , , -
 -
 1993 . 4804-1 « 15 », -
 () .
 () ó
 , 1899 .

¹ .: 5154962000. -
 .- « ».

(. 92).



. 91.



. 92.

(10 15)(. 93).

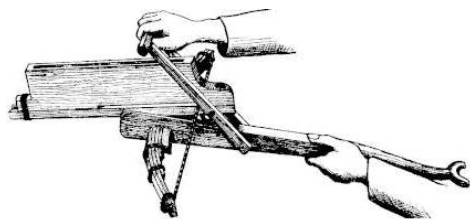

. 93.

. 94.

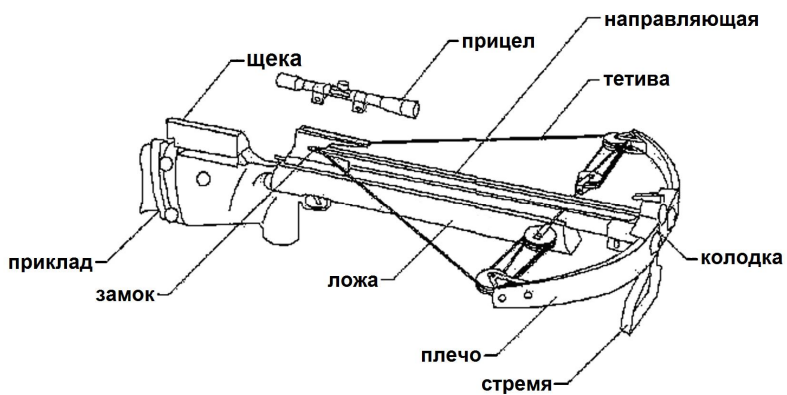

. 94.

()

(), (),

(. 95).



. 95.

() ,
 ó ()
 ,
 () .
 ,
 ;
 ;
 () .
 , ó (.96).



. 96.

, () ,
 (.97).



. 97.

.).

90

(. 99).



. 99.

« » (. *pied de biche*) (. 100).

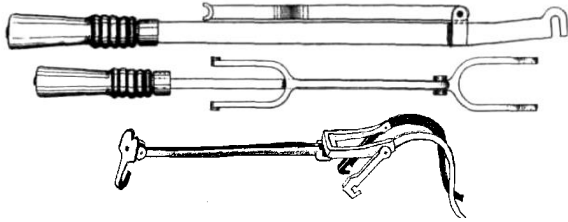

. 100.

« »

« »

ó
ó
ó

(. 101).

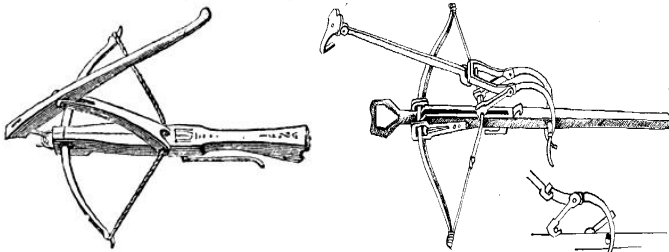

. 101.

« »

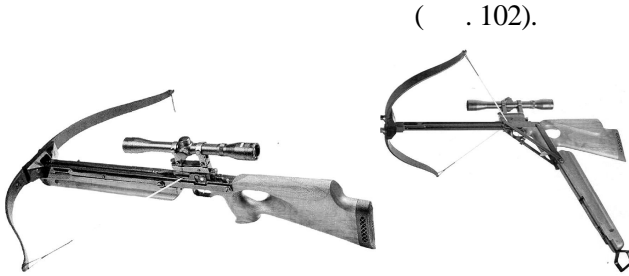

(. 102).

. 102.

»

(. 103).



. 103.

Crankaroo
Excalibur

(. 104).



. 104.

, 50%.
 (-
),
 (),
 (. 105).

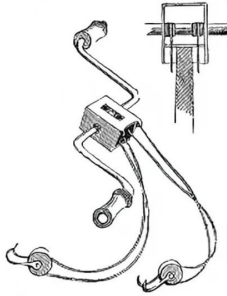

. 105.

- ()
 -
 , () -
 .
 ,
 , ó -
 ,
 ,

68 (150 lbs).

(. 106).



. 106.

(
)
(. 107).

(. 108).



. 107.

() ();

()

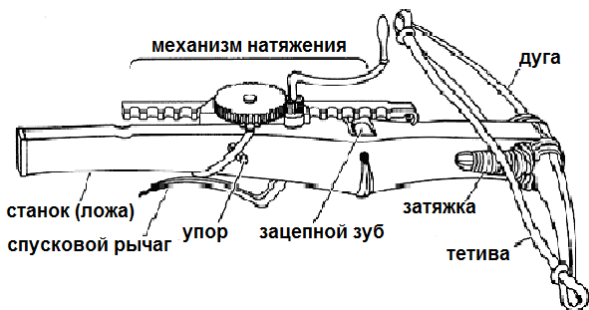

. 108.

();
()

(, , б , -
 , -
).
 б , -
 () . б , -
 (. 109).

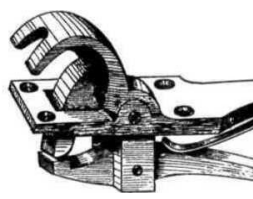

. 109.

ó

()

()

8 (0,8)

« », (. 110).

150

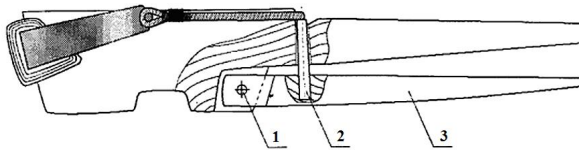
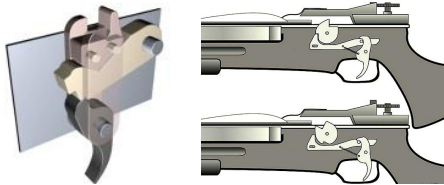

. 110.

1 ó

(); ; 2 ó () ; 3 ó ().

ó

ó

(. 111).

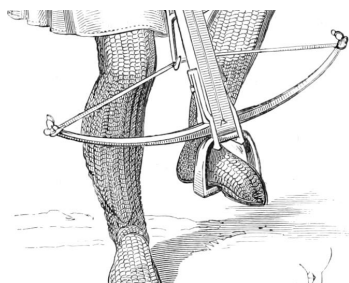

. 111.

()

150 (15,3),

« » « »

)

().

() ()
(.112).



.112. ()
()

ó (), (.113).



.113.

(),

()

Dot), (Mil

ó

()

ó

()

(Weaver) « » (. 114).



. 114. (Weaver) (); « » ()

ó ,

.
() () () , -
) () () () -

.
, , -
, -

.
, -
, -

, -
, -
, -

, -
, -
ó « » , ó (-
) .

, -
, -
, -

, -
, -
, -

, -
, -
, -

ó
ó
ó
ó

(. 115):



. 115.

(); -
(); - ()

ó

ó

ó

ó

30640 , 200 .

(, ,) .
 (,)
 () . (, ,) .
 .
 , .
 , .
 .
 (.2).
 2

	30	10
, ,	6	4,5
, ,	15	10
, ,	0,5	

, -
 ,
 (, -
). , , -
 .

ó
 ó
 ó

:
 ó (.116);
 ó 60° (
 ó);
 ó

2 ;
 ó 3046457 .

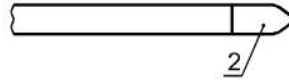
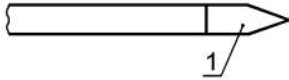

. 116.
 1 ó ; 2 ó

, -
 .
 .
 , -
 .

ó
 ó

:
 ó 3556610 .
 ó

2.2.4.

, . -
 , .
 :
 ó - ;
 ó ;
 ó

« » (. 117).

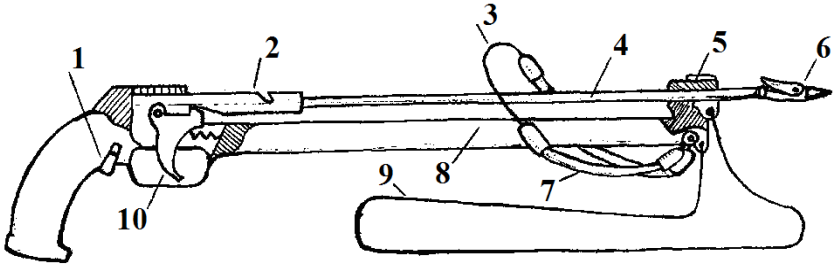

. 117.

1 ó ; 2 ó ; 3 ó ; 4 ó ; 5 ó ; 6 ó ; 7 ó ; 8 ó ; 9 ó ; 10 ó ;

668

80061 200

() .

() (. 118, 119).



. 118.



. 119.

(. 120).



. 120.

(. 121)

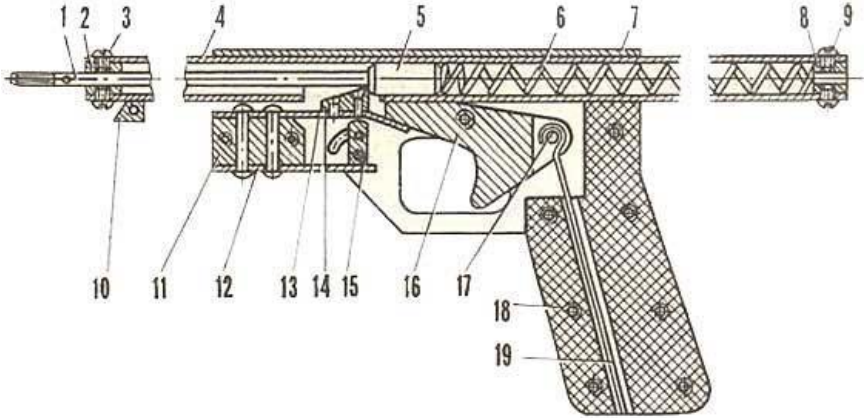

. 121.
1 ó ; 2 ó ; 3 ó ; 3; 4 ó ;
5 ó ; 6 ó ;
7 ó - ; 8 ó ; 9 ó 3;
10 ó ; 11 ó ; 12 ó ;
13 ó ; 14 ó ;
15 ó ; 16 ó ;
17 ó ; 18 ó ;
19 ó

95 (. 122).

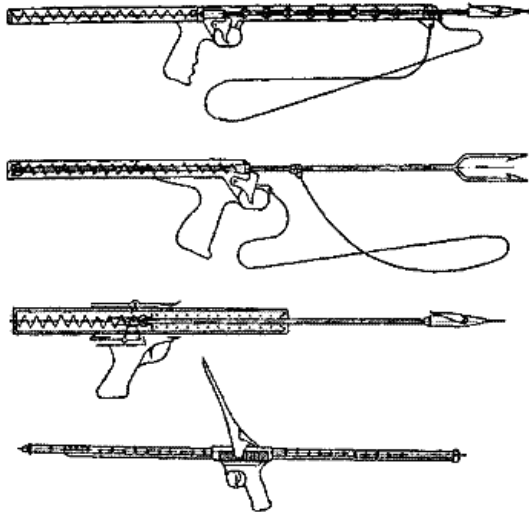

. 122.

()

3.1.

()

, (, ,), , .

()

, , , , .

(

)

1.

)

(-
-

1

(,) .
, , .

1. , , :

2. , ?

3. ?

() ()? -

-

, -

, : « , -

?», « -

() ?» . .¹ , (-

) ()

, .

, , , -

, , -

) -

, -

() -

, , -

() . (-

, ,) .

¹ .4
21 2010 . 28 « -
» , , -
 , , -
 . , , ,

) , (-
 , , -
 . , -
 .) (-
) , -
 ,
). ,
 ,
 () ,
 ,
 () ,
 . () -
 -
 .
 .10 .4 .57 .
 .10 .6 « -
 » , , -
 , -
 , -
 . , -
 , -
 . () , -
 . , -
 . () , -
 , -
 , , -

.
 , (, ' () -
 ,) .
 , 1. , -
 0,1 ,
 () () ó 1 , -
 () (,) ó 1 , -
 () , ó ±5 % ,
 (,) ó
 9013659.
 () -
 , -
 , , -
 , . . , -
 45680 % 10635 ° ,
 .
 () , -
 . , -
 , , -
 , , -

 1 -
 , -
 , -

(ó 2, 9, 10 . .). 365^x , -

1. , -
() , -

· , -
(, ó , , -
) , -

- () , -

· , -
, -

, , -
- , -

() , -
, -

1 () , -

, () , -

, , « -
 » -
 , « », -
 . -
 , -
 () -
 , , -
 . , -
 , -
 (), -
 - () -
 , -
 , , « , -
 , , , -
 , , , -
 » , « -
 , , -
 ». -
 (, « », -
 ; -
 ; -),
 (, 1. -
),

1

- , ,
 , ,
 -
 , ,
 . ,
 -
 ,
 (,).
 -
 -
 , ,
 -
 .
 -
 :
 ó ()
 ;
 ó -
 - .
 :
 ó - (,
 (), ó
 . .);
 ó (, ó
 (), ó . .)
 ;
 ;
 ó (, ,
 , , ,
 ó ().

(, ' , -
ó ' -
()).

, . -
() . -
(.).

ó 10 50 . (-
) . -
.

;

(-);

(-)¹;

ó -

() , -

1

() « »¹,
 ()
 2.
 ()
) (-
 () , -
 , -
 , -
 , -
 (,) ,
 () ,
 (, -)

1 « » 6
 2
 6 , ,
 364 , ,

3.2.

()

()

, - , -

.

, -

,

, .

, -

, , -

, , -

, , -

.

, ,

() ,

,

.

(-

)

, , , , ó .

()

- .

, -

, -

.

() -

:

;

;

, ; -

.

-

, . , -
 :
 1) : ;
 ó ;
 ó ;
 ó () ;
 ó ;
 ó . ()
 :
 ó ;
 ó , , , , ;
 ó ó , , ;
 ó ó , , ;
 ó ó , , ;
 ó ó , , ;
 ó () ó , , ;
 ó () ó , , ;
 ó , ;
 ó () ;
 ó , , , ;
 ó , . ó -
 : -
 , , ,
 . ,
 () :
 ó ;
 ó ;
 , ;

ó , ;
 ó ;
 ó , , -
 , ;
 ó ;
 ó (, -
 , , .).
 : -
 ; , . -
 , -
 . -
 . -
 , -
 (, -
). -
 () , -
 . -
 () -
 : . -
 . -
 () -
 : . -
 () « » ,
 ,

(. 123, 124)¹.

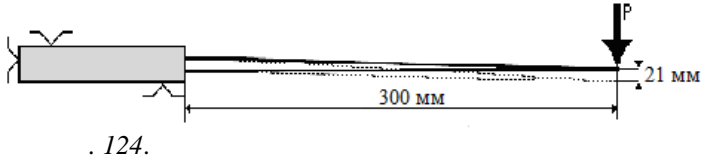
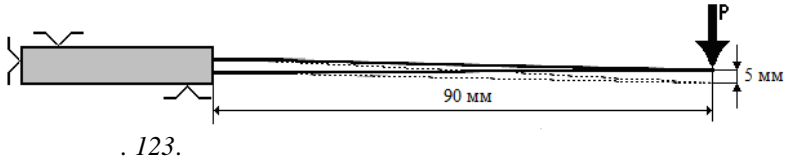

-
 , 1' .
 -
 ()
 -
) 10612 (5
 ()
 -

9013659
 DIN50103; ASTM E 18674;

2039/2681;

2) ;
 ó ;
 ó , ;
 ó ;
 , , , ;
 ó ();

¹ 90-
 () 5 25
 2)
) 21 25 (-
 2

10 . () 5¹, ó -
 , . . (, -
), , -
 . -
 (,) -
 , -
 . -

3.3.

, ó . -
 , -
 « , 5190562002
 . »,
 5211562003 « , -
 . » 5171562001
 « , -
 », 5154962000 « -
 . -
 ».

1

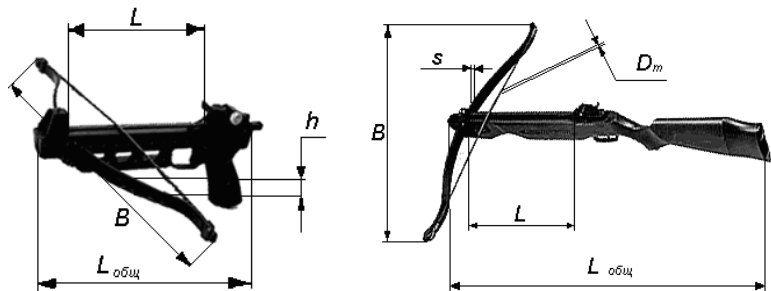

. 125. :
 B ó () , ; h ó , ;
 s ó , ; L ó , ;
 D ó , ; L ó , ;
 :
 ó ;
 ó , , ;
 ó ;
 ó (, , ,) ;
 ó , (, , ,) ,
 (. 126);

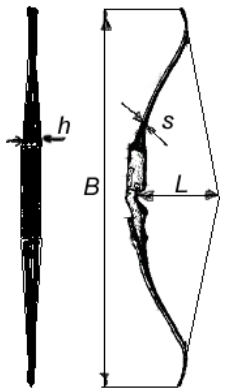

. 126. :
 B ó () , ; h ó , ;
 s ó , ; L ó , ;

ó (), -
 ;
 ó , , ();
 ó , , ;
 ó , , ;
 ó , , ;
 ó (,) :
 ó ((,));
 ó);
 ó : , -
 ;
 (, ,);
 (, -
);
 ; , -
 ; ,
 ; ,
 ;
 ó ;
 ó , .
 (). , () .
 , () -
 (), , -
 , ,
 . () -
 , -
 . , -
 ,
 .
 :
 ó ;

ó , : ; ; ;
ó ; - ; ;
ó ; , -
ó ; ;
ó , . -
() , -
ó , -
« », . . . -
, . . . -
- , -
, -
(,). -
, -
.

, -
 . , -
 , . -
 (). () -
 , -
 () -
 800 -
 () -
 () , -
 (. 5.1 . 1, . -
 27.12.2006 386-). -
 5211562003 « -
 , -
 . -
 » -
 -

(. 127).

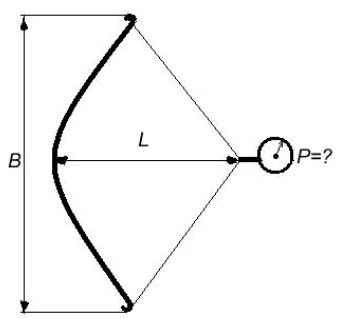

. 127. () 6 , ()

() () .
 () ()
 (. 128).

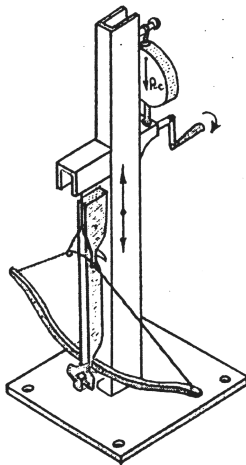

. 128.

(
 « - » ,
)

),
 ()
 10 .

(
 5610 .

) 10 ,
 5 .

(
 ó ,
 () ,

. ()
 .
 ,
 . (,
)
 0 150 (15,3).
 .
 ,
 -
 -
 -
 .

1. : . 30 2001 . 195- (. 19.07.2018). ó .- « - ».
2. - 18 2001 . 174- (. 19.07.2018). ó .- « ».
3. 13 1996 . 63- (. 03.07.2018). ó .- « ».
4. : . 31 2001 . 73- (. 08.03.2015). ó .- « - ».
5. , , , : 12 2002 . 5 // . ó 2002. ó 5. ó .2.
6. : 21 2010 . 28. ó .- « - ».
7. : . 13 1996 . 150- (. 19.07.2018). ó .- « - ».
8. -
9. : 30 2017 . 429. ó .- « ».
10. 51215698. . « ».
10. 5154962000. .

11. 5171562001. « - ».
12. 5190562002. « ».
13. 5211562003. « ».
1. , . . , . . .
2. , . . : . - . / . . , ó : , 2005.
3. , . . : . - . / . . , ó : , 2016.
2017. ó 4 (52). / . . // . ó
4. , . . , . . . / . . - // . ó 1993. ó . 7.
5. , . . / . // . ó 1996. ó 7/8.
6. , . . / . . // . ó
- . 1 / ó : - . . - , 1996.
7. , . . : . . / . . . ó : , 2002.

20. . . . /
. . . . ó - : , 2001.
21. . . . (-
): 3 . . 2 :
/ ó : . . . , 2001.
22. . . . (,
) VIII ó XIV . / ó : , 1966.
23. . . .
/ ó : , 1987.
24. : . -
-
(5 18.11.1998). ó URL: napoleonic.ru
: 17.02.2014).
25. . . . / ó :
; - : , 2003.
26. -
-
: . . . / . . . [.]. ó :
, 2003.
27. - , : . - . ó : ,
2007.
28. ó // . ó 1994. ó . 1.
29. ó 4- „ . -
. / ó : , 2010.
30. . . . / ó
: , 1993.
31. . . . / . . . -
. ó : , 1993.
32. , . . . /
. . . . ó : , 1989.
33. . . . :
. . . . ó : . . . - . . . , 2003.
34. , . . . : . . . /
. . . . ó : , 2001.

()

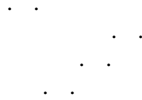

*alicdn.com, classic.ru, popgun.ru,
reactor.cc, selcdn.ru.*

400089, . , . , 130.

400131, . , . , 36.

17.07.2019. 60×84/16.
Times New Roman. . . 8,25. . . . 7,67.
100. 35.

. 400131, . , . , 36.